

Kirchhoff's Rules

Equipment

Qty	Items	Parts Number
1	AC/DC Electronics Laboratory	EM-8656
4	Patch Cords	SE-9750
1	Current Sensor	CI-6556
1	Voltage Sensor	UI-5100
4	Alligator Clips	
6	Resistors: 100 Ω , 200 Ω , 330 Ω	
1	Two prong adaptor	

Purpose

In this activity we will be examining the means to analyze the voltages and currents passing over circuit components via Kirchhoff's Rules.

Theory

Whenever a circuit is complicated (sometimes known as a network), analyzing it by application of the formulas for resistors in parallel or in series becomes impractical (or impossible). In such cases, the analysis of the circuits can be done with the help of **Kirchhoff's Rules**. The rules are direct consequences of two fundamental principles: The Conservation of Energy – The total amount of energy in a closed system is conserved, and The Conservation of Charge – The net charge in a closed system is conserved.

Kirchhoff's Rules:

The Loop Rule – The net change in electric potential difference around any closed path in a circuit sums to zero.

$$\Delta V_{net} = \sum_j^n \Delta V_j = 0$$

The Junction Rule – The net current entering a junction must be equal to the net current leaving that same junction.

$$\sum_j^n i_j = \sum_k^m i_k$$

The loop Rule is a consequence of the Conservation of Energy. Since the electric potential energy a bit of charge has is a function of its location in an electrical field, if a bit of charge

starts at a random location in a circuit, then travels around that circuit only to return to the exact same location that it started from, then it must have the exact same electric potential energy at that location as it did when it started its journey. This results in the net change in electric potential difference being zero along whichever path it took.

The Junction Rule is a consequence of the Conservation of Charge. *A Junction is any location in a circuit where three or more branches of a circuit meet, and therefore give the current multiple paths to travel along.* Since the amount of charge can't change, any bit of charge that enters a junction must also leave that same junction, and this results in the amount of current entering a junction being equal to the amount of current leaving that same junction.

How to apply The Loop Rule: Let us start off with a diagram of a circuit. To the right there is a diagram of a circuit consisting of an electric potential source, and four resistors.

1. First we need to pick a location in the circuit, then pick a path (loop) to travel around the circuit returning to the original location. It is common, but not required, to pick the potential difference source as the original location. (A valid loop is not even required to have an electric potential source in it)
2. Then Let us pick the path (loop) starting from the potential difference source, then moving over resistor 1, then resistor 2, and then finally returning the potential difference source.
3. Now we need to label the ends of the circuit components that are in our loop either positive or negative based on their relationships to our potential difference source. The side of a resistor that is directly connected to the positive side of the potential difference source will be positive, its other side will be negative, and vice versa. (If there are multiple resistors in series then all the resistors in series will have the same sides labeled as positive, and the same sides labeled as negative)

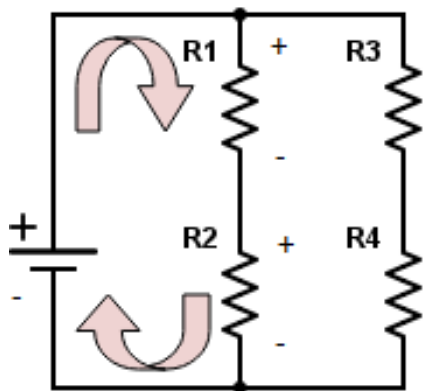
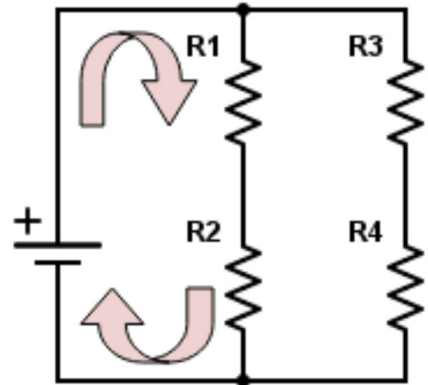
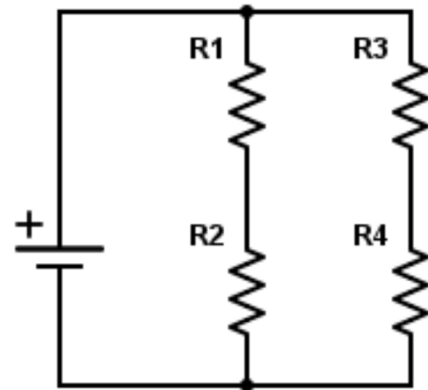

4. From Ohm's Law The potential difference over a resistor will have the magnitude of $\Delta V_j = i_j R_j$
5. We will write our Loop Rule equation as we travel around our loop. When you move over a circuit component traveling from the negative side to the positive side (also known as moving from a low potential to a high potential) the potential difference of that component will have a positive value. However, when you move over a circuit component traveling from the positive side to the negative side (also known as moving from a high potential to a low potential) the potential difference of that component will have a negative value. Finally, the equation always equals zero.
 - In our example, where we start at our potential difference source moving from its negative side to its positive side, then over resistor 1, moving from its positive side to its negative side, then over resistor 2, moving from its positive side to its negative side, then finally returning to our potential difference source we get the following equation;

$$\Delta V - i_1 R_1 - i_2 R_2 = 0$$

How to apply the Junction Rule: Let us start off with the same circuit diagram as before. This diagram has two junctions in it. The Junction at the top, where the current coming from the potential difference source that can either enter the branch that will make it pass through resistor 1, or it can enter the branch that will make it pass through resistor 3. This gives us the junction equation;

$$i = i_1 + i_3$$

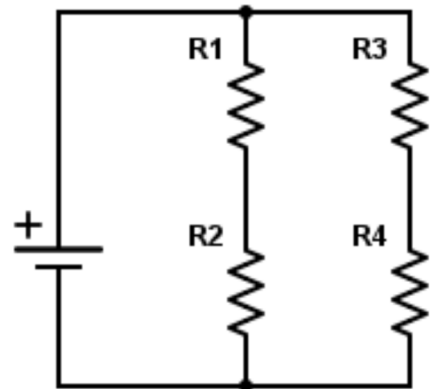

It also has the junction at the bottom, where the currents that passed over resistor 2, and resistor 4 enter the junction, and then combine to become the current that is leaving the junction to entering the potential difference source. This gives us the junction equation;

$$i_2 + i_4 = i$$

There is something that should be noted about these two junction equations: *they are the same equation!* The first one is the current coming from the potential difference source entering a junction, and then splitting off into two different branches of the circuit. The second equation is the current from those same two branches entering a junction, and combining to be the current

entering the potential difference source. Remember, by conservation of charge we know that all the currents passing over resistors in series must be the same. (In this example that means that $i_1 = i_2$, and $i_3 = i_4$) When applying the Junction Rule to a circuit *there will always be at least one pair of junction equations that are mathematically redundant, and therefore you can only use one of those equations to help you solve the circuit.*

It is said you 'solve the circuit' by applying these two rules to a circuit as many times as needed till you have constructed as many mathematically independent equations as there are unknowns. (If there are 5 unknowns, then you need 5 mathematically independent equations) Then you solve those equations for the unknowns, by either the substitution method or putting them in a matrix.

Setup

1. Make sure the 850 Universal Interface is turned on.
2. Open the Capstone software. On the left side of the main screen is the Tool Bar. Click on the Hardware Setup icon. This will open the Setup window.
 - Click on the Channel A of the picture of the 850 Universal Interface in the Setup window, and then scroll down, and add the 'Current Sensor'.
 - Plug in the Current Sensor into Channel A.
 - Plug two patch cords into the Current Sensor.
 - Click on the Output Channel 1 of the picture of the 850 Universal Interface in the Setup window, and add 'Output Voltage-Current Sensor'.
 - Plug in two patch cords into Output Channel 1.
 - Plug the other ends of these patch cords into the AC/DC Electronics Laboratory.
3. Bottom middle of the main window, there is the sample rate settings.
 - Select 'Common Rate'.
 - Set the rate to 1 Hz.
4. Right to the right of the sample rate click on 'Recording Conditions'. This will open up the recording conditions window.
 - Click on "Stop Conditions".
 - Set condition type to "Time Based".
 - Set Record Time to 1 second.
 - Click 'ok', to close the Recording Conditions window.
5. On the Tool Bar click on the "Signal Generator" Icon. This will open up the Signal Generator window.
 - Click on '850 Output 1'.
 - Set waveform to 'DC'.
 - Set DC Voltage to 5.0 V.
 - Set Voltage Limit to 10.0 V.
 - Set Current Limit to 1.50 A.
 - Click on 'Auto', so the data will stop and start collecting when you click on 'record'.

- Close the Tool Bar.
6. On the main page, from the Quickstart Templates options, select the 'Two Large Digits'.
 - Click on 'Select Measurement' for the top display, and select 'Current, Ch A (A)'.
 - Click on 'Select Measurement' for the bottom display, and select 'Output Voltage, Ch 1 (V)'

Procedure

1. In the various circuit setups, R1 & R4 are 100 Ω , R2 & R5 are 200 Ω , and R3 is 330 Ω resistors
2. Using a multimeter, measure the actual resistance of each resistor and record the measured values in the tables for each of the following setups.
3. For each of the setups V1 = 5.0 V, and V2 = 3.0 V. Record these values in the tables for each setup.
4. Using the listed resistors and a few of the small wires, construct the circuit for Setup #1 on the AC/DC Electronics Laboratory.
5. Attach the alligator clamps to the end of the Current Sensor.
 - Attach the Current Sensor probe in series with resistor R1.
 - Click 'record'.
 - In the table for setup #1, record the measured Current for the R1, and record the Output voltage, and the Output Current.
 - Then measure the current for the rest of the resistors, and record their currents in the table for setup #1.
6. Then repeat whole process for the three other setups.

For Setups #4 you will need to add an additional potential difference source.

1. Near the top left corner of the main window, click on the 'Change properties of current page and Tools Palette' icon. This will open the properties window.
 - Click on 'Page Options'
 - Click the box for 'Show Tools Palette'. This will reopen the Tool Bar.
 - Click 'ok' to close the properties window.
2. In the Tool Bar, click on the 'Hardware Setup' Icon.
 - On the picture of the 850 Interface click on the Output Source 2.
 - Select 'Output Voltage Sensor'.
3. In the Tool Bar, click on the 'Signal Generator' icon.
 - Click on '850 Output Source 2'.
 - Set Waveform to 'DC'.
 - Set DC Voltage to '3.0 V'.
 - Set Voltage Limit to '10.0 V'.
 - Click on 'Auto', so the voltage source will turn on and off when you start and stop collection data.
 - Close the Tool Bar.
4. Physically attach the two prong adaptor to Output Source 2 on the 850 Pasco interface.

- Plug in two patch cords to the adaptor, and attach alligator clips to the ends of those two patch cords.
5. Near the top left of the main window click on the 'Add Page' icon.
 6. From the Quickstart templets select the 'Four Displays' option.
 - From the Displays bar, on the right side of the main screen, drag and release the 'Digits' display onto the top left display, and then repeat for both displays on the right, resulting in only having three displays available.
 - For the top left display click on 'Select Measurements', and then select 'Current, Ch A (A)'.
 - For the top right display click on 'Select Measurements', and then select 'Output Voltage, Ch1 (V)'.
 - For the bottom right display click on 'Select Measurements', and then select 'Output Voltage, Ch2 (V)'.

Setup #1

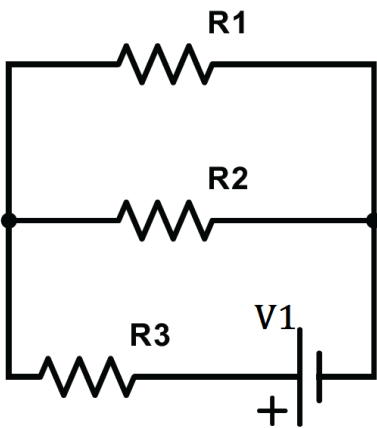

Setup #2

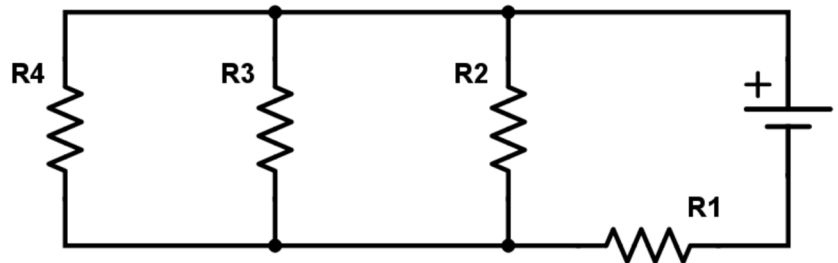

Setup #3

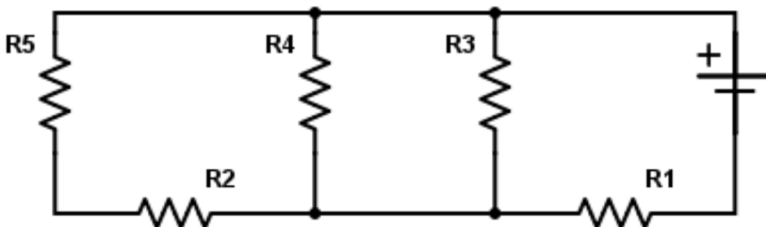

Setup #4

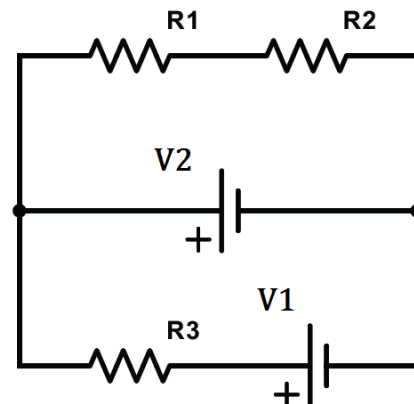

Analysis of Kirchhoff's Rules Lab

Name _____ Group# _____

Course/Section _____

Instructor _____

Table 1 (5 points)

$\Delta V1$ _____

	$R(\Omega)$	$i_m(A)$	$i_t(A)$	% Error
R1				
R2				
R3				

1. Using Kirchhoff's Rules, construct enough mathematically independent equations to solve for the current of each resistor. Then calculate the % error between your measured and theoretical values for the current of each resistor. You MUST use Kirchhoff's Rules and show work to receive any credit. (15 points)

Table 2 (5 points) $\Delta V1$ _____

	R(Ω)	i_m(A)	i_t(A)	% Error
R1				
R2				
R3				
R4				

2. Using Kirchhoff's Rules, construct enough mathematically independent equations to solve for the current of each resistor. Then calculate the % error between your measured and theoretical values for the current of each resistor. You **MUST** use Kirchhoff's Rules and show work to receive any credit. (15 points)

Table 3 (5 points) $\Delta V1$ _____

	R(Ω)	i_m(A)	i_t(A)	% Error
R1				
R2				
R3				
R4				
R5				

3. Using Kirchhoff's Rules, construct enough mathematically independent equations to solve for the current of each resistor. Then calculate the % error between your measured and theoretical values for the current of each resistor. You MUST use Kirchhoff's Rules and show work to receive any credit. (15 points)

Table 4 (5 points) $\Delta V1$ _____ $\Delta V2$ _____

	R(Ω)	i_m(A)	i_t(A)	% Error
R1				
R2				
R3				

4. Using Kirchhoff's Rules, construct enough mathematically independent equations to solve for the current of each resistor. Then calculate the % error between your measured and theoretical values for the current of each resistor. You **MUST** use Kirchhoff's Rules and show work to receive any credit. (15 points)

5. In the theory section of this worksheet, detailed explanations are given as to how Kirchhoff's Laws are connected to conservation laws. Briefly, and in your own words, summarize each of these explanations. (10 points)

6. Did our experiments confirm the theory? Justify your answer. (10 points)